

# 1 – Security

Read the following safety instructions carefully before using the product for the first time and follow the instructions in this manual to avoid injury or damage to the product. Always carry this manual with you when using the product so that you have it available as a reference at all times. Pass this manual on if you pass the product on (e.g. sell or lend it) and contact the manufacturer (see page 2) if you have any questions or concerns about using the product.

## 1.1 Safety instructions

- Only use the product within the operating and environmental conditions specified in the product specifications.
- Do not use the product near people with pacemakers or other medically necessary electrical devices.
- Do not repair, disassemble or modify the product yourself.
- Opening and/or repairing the product can lead to electric shock, product damage, fire, personal injury and other hazards.
- Do not immerse the product in liquids or spray it directly with liquids.
- The product is only water and dust resistant when properly closed. Do not expose the product to the weather when it is open and do not operate it with damp or wet hands.
- Remove water from the product with a dry, soft cloth before opening.
- Do not expose the product to direct sunlight.
- Do not use the product if it is damaged or not working properly.
- Only charge the COBOX with the power cable provided. The voltage limits of the input voltage are 90 V to 264 V. The mains frequency must be in the range between 50 and 60 Hz.
- The Ethernet cable must not exceed a length of 3 meters.
- Only charge the battery-equipped components of the product with the power supply specified in the product specifications.
- Do not charge the battery-equipped components of the product continuously.
- Disconnect the components from the power supply when they are fully charged.
- Only operate the product with the original accessories or accessories authorized in writing by the manufacturer. Do not charge any other devices with the product.
- Do not bend or kink the cables too much or place heavy loads on them.
- Fully charge the battery before using it for the first time.
- Only charge the AUDAs in the slots on the COBOX.
- If the product is not used for a long period of time, fully charge the battery every four

months.

- Only clean the product with a dry, clean cloth when it is switched off.
- Only store the product in a dry and dust-free place.
- Only place and operate the product on a flat, non-sloping surface.
- When you receive the product, check that all parts are present and free from damage. If any components are missing or damaged, contact the manufacturer.
- The product can be used by children aged 8 years and above and by persons with reduced physical, sensory or mental capabilities or lack of experience and knowledge if they are supervised or have been instructed on how to use the product safely and understand the resulting risks.
- The product, its accessories and its packaging material are not toys. Do not let small children play with them, as small children can injure themselves or others or damage the product. Keep the product with all its parts and accessories and its packaging material out of the reach of small children.
- Air transport should be in hand luggage.
- For air transport, the Audas must be removed from the Cobox (galvanic isolation from the main battery of the Cobox) and transported separately.
- The charge level of the batteries should be max. 30% during transport.
- If you have any questions, contact the airline before boarding the flight.

## 1.2 Conformity

Coachwhisperer GmbH hereby declares that the products “COBOX” (Article No.: CW-0002-0A-R-0001) and “AUDA” (Article No.: CW-0005-0A-R-0001) conform to the requirements of Directive 2014/53/EU. The full text of the declaration of conformity can be viewed at [www.coachwhisperer.de](http://www.coachwhisperer.de).

Warning: The operation of this device or this equipment can cause radio interference in the residential area.

## 2 – Specifications

COBOX	
Article number	CW-0002-0A-R-0001
Dimensions (L x W x H)	521 x 292 x 183 mm
Weight	approx. 5000 g
Power supply	230 V (AC), 50 / 60 Hz
Connectivity	WLAN   Bluetooth
Frequency band	2,412 GHz to 2,472 GHz (WLAN)   2,402 GHz to 2,48 GHz (Bluetooth)
Maximum transmission power	EIRP: 19,99 dBm (WLAN)   EIRP 9,6 dBm (Bluetooth)
Environmental conditions	Operation: -30 °C ... 60 °C (weatherproof) Charging: 0 °C ... 45 °C Storage: -20 °C ... 60 °C
Protection class	Protection class II   IP67

AUDA	
Article number	CW-0005-0A-R-0001(AUDA) CW-0006-0B-HW-0001 (Loudspeaker)
Dimensions (L x W x H)	70 x 50 x 15 mm
Weight	100 - 150g

AUDA	
Power supply	5 V (DC)   0,7 A
Connectivity	WLAN   Bluetooth
Frequency band	2,412 GHz to 2,472 GHz (WLAN)   2,422 GHz to 2,462 GHz (WLAN)   2,402 GHz to 2,480 GHz (Bluetooth)
Maximum transmission power	EIRP: 19,22 dBm (WLAN)   EIRP: 7,93 dBm (Bluetooth)
Environmental conditions	Operation: -10 °C ... 60 °C Charging: 0 °C ... 45 °C Storage: -10 °C ... 60 °C

SOUNDVEST	
Item number	CW-0006-MEC-0B-0001
Sizes (length x chest)	S (33 x 36 cm) M (34 x 38 cm) L (35 x 40 cm) XL (36 x 42 cm) XXL (37 x 44 cm)
Material	82 % Nylon 18 % Elastane

# 3 – Transport

## Scope of delivery

The following components are included as standard:

- COBOX (including power cable for power connection)
- AUDA (including integrated loudspeaker)
- SOUNDVEST
- Instruction manual

## Delivery

The product is packaged as required upon delivery. Before first use, check the delivery for the following:

- Completeness of the product components
- Integrity of the packaging and all components contained
- Completeness and accuracy of the delivery documents

In case of defects or damage, report them immediately to the manufacturer and the responsible supplier and document defects or damage.

## Transporting the product

The COBOX has an extendable handle and integrated wheels.

1. Disconnect all connections from the COBOX.
2. NOTE: Store the power cable in a separate storage area, not in the COBOX.
3. Store the AUDAs in the recesses of the COBOX.
4. Close the case cover completely and secure it with the locking clips.
5. Press the locking button on the handle of the case and pull it out until it clicks into the extended position.
6. Transport the COBOX to the desired location.

## 4 – Description

The „Coachwhisperer“ system is used for communication between coaches and athletes in real time via a local network. Communication is controlled via the graphical user interface of an internet-enabled device (not included). The web-based application is required to use the system (contact our customer service for further information). The access data is provided separately by email. The system consists of a base station (COBOX) and several portable receivers (AUDA) and a sound vest (SOUNDVEST) with integrated loudspeaker.

### 4.1 Cobox

The COBOX consists of a portable case in which up to 27 AUDAs can be transported, stored and charged. The AUDAs are assigned to the players via the integrated touchscreen.

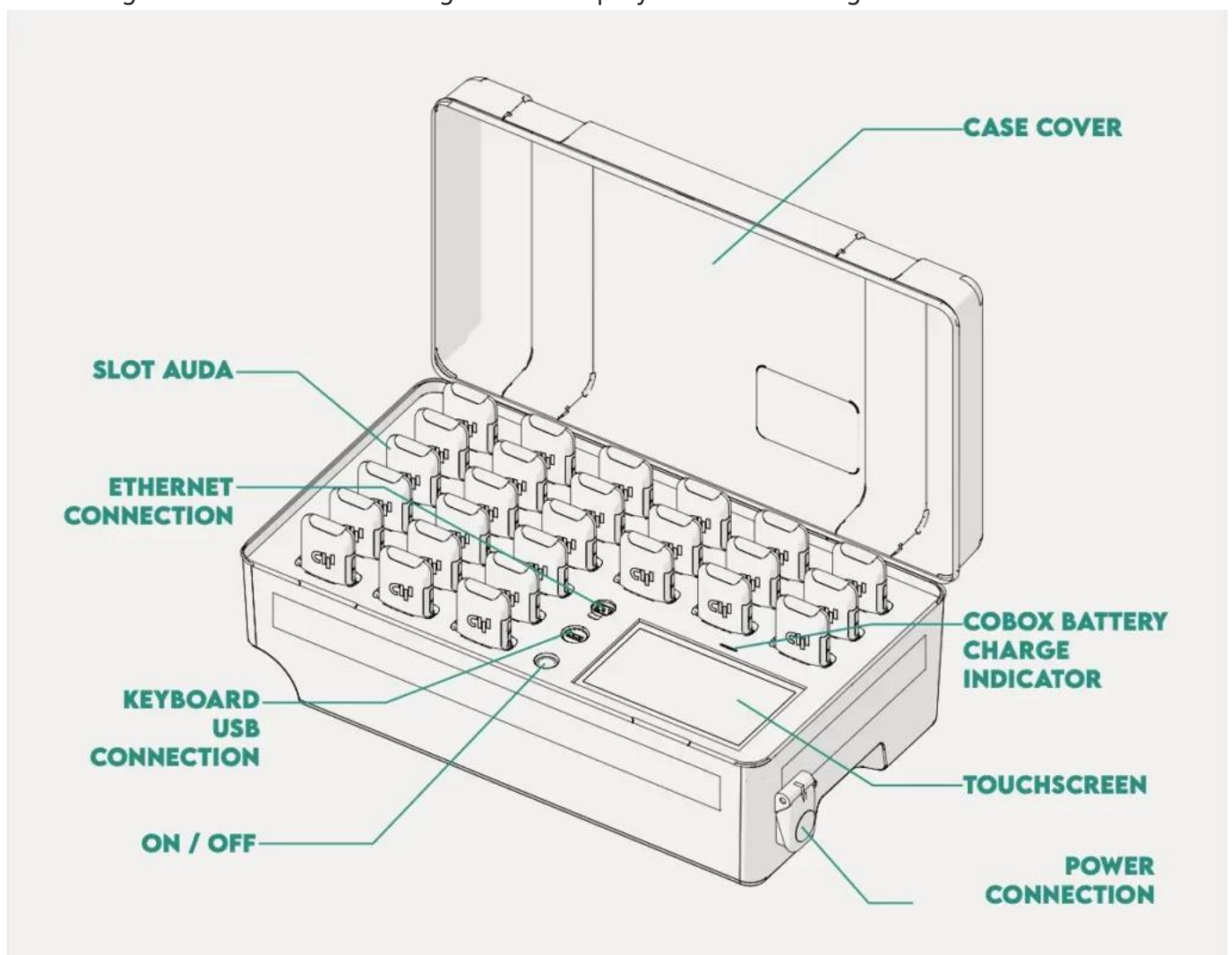

## 4.2 Auda

The AUDA is worn by the players on their bodies or in an optionally available and specially developed sound vest (SOUNDVEST). It enables data to be received from the coach to the player.

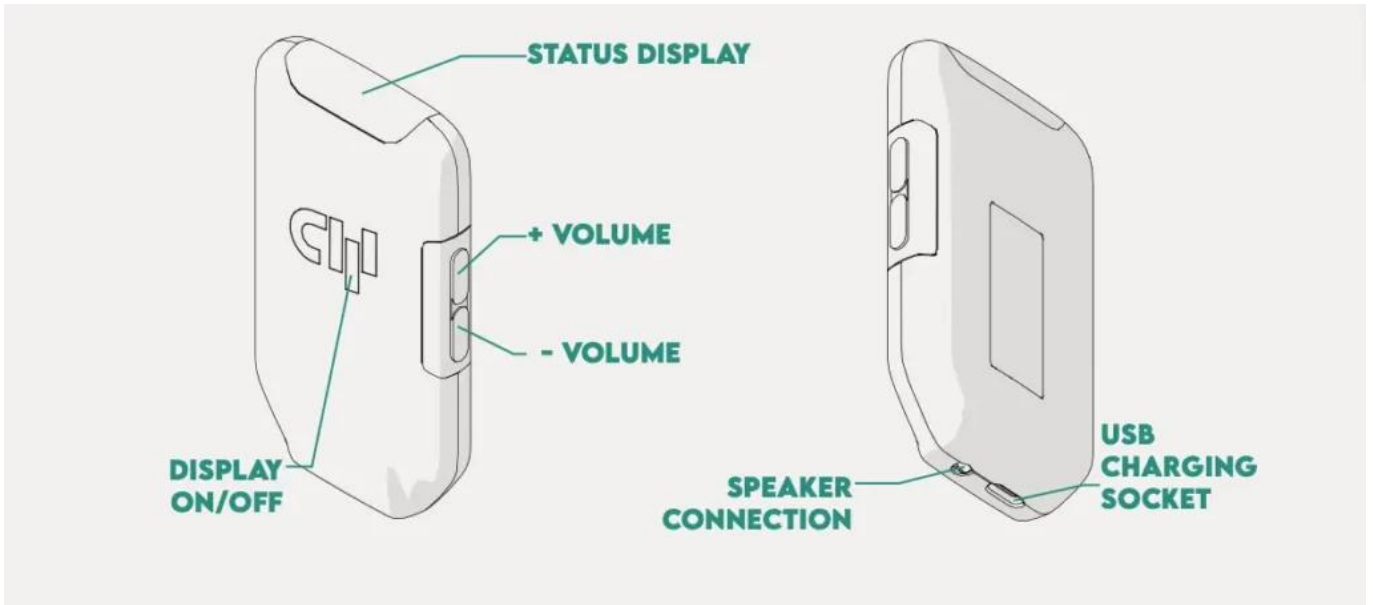

## 4.3 Soundvest

The SOUNDVEST is a vest that is used to safely store the AUDAs during use. A pocket on the back allows the AUDA to be optimally positioned and connected to the loudspeaker pre-mounted in the SOUNDVEST.



# 5 – Preparations

## 5.1 Turning on for the first time

- Fully charge the COBOX and the AUDAs before using them for the first time.
- Turn on the COBOX (see section 5.3).
- Set up the Wi-Fi on the COBOX (see section 5.6).

## 5.2 Charging the Cobox

The COBOX has an integrated battery that is charged via the power connector on the side of the case.

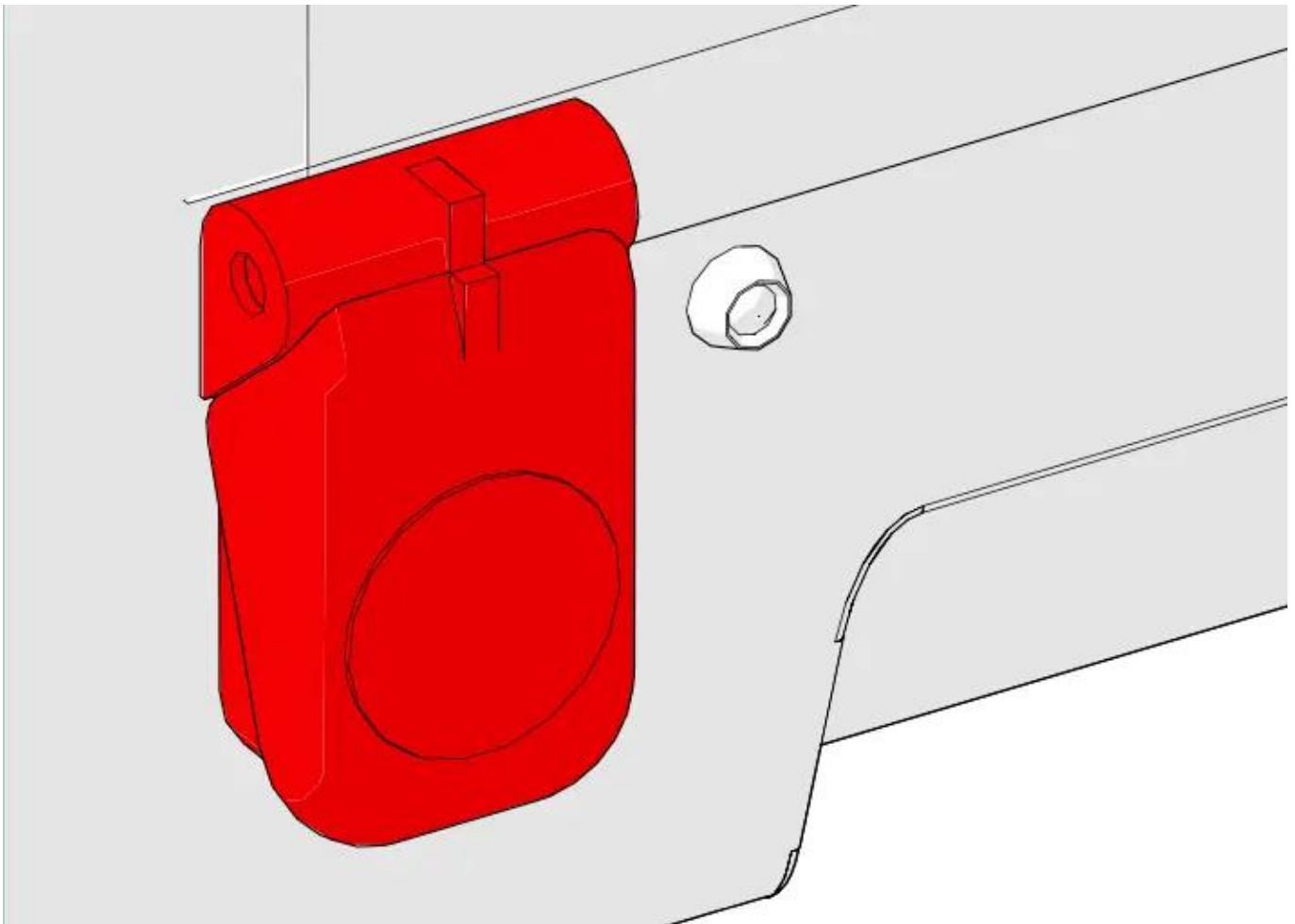

1. Close the case cover.
2. Flip up the power connector cover.
3. Connect the supplied power cable to the power connector on the side of the COBOX.



4. Connect the power cable plug to a power outlet

- ✓ The COBOX is charging.
- ✓ The LED next to the power connector lights up.

The LED next to the power connector lights up depending on the charging status:

- Flashing green: Battery is charging
- Solid green: Battery fully charged
- Red: Error

## 5.3 Turning the Cobox on/off

### Turn on the Cobox

- Make sure that the COBOX is sufficiently charged (see section 6.1).
  - Open the cover of the case.
  - Press the ON / OFF button to turn on the COBOX.
- 
- ✓ The ON/OFF button starts flashing.
  - ✓ When the COBOX has fully booted up, the ON/OFF button lights up continuously.

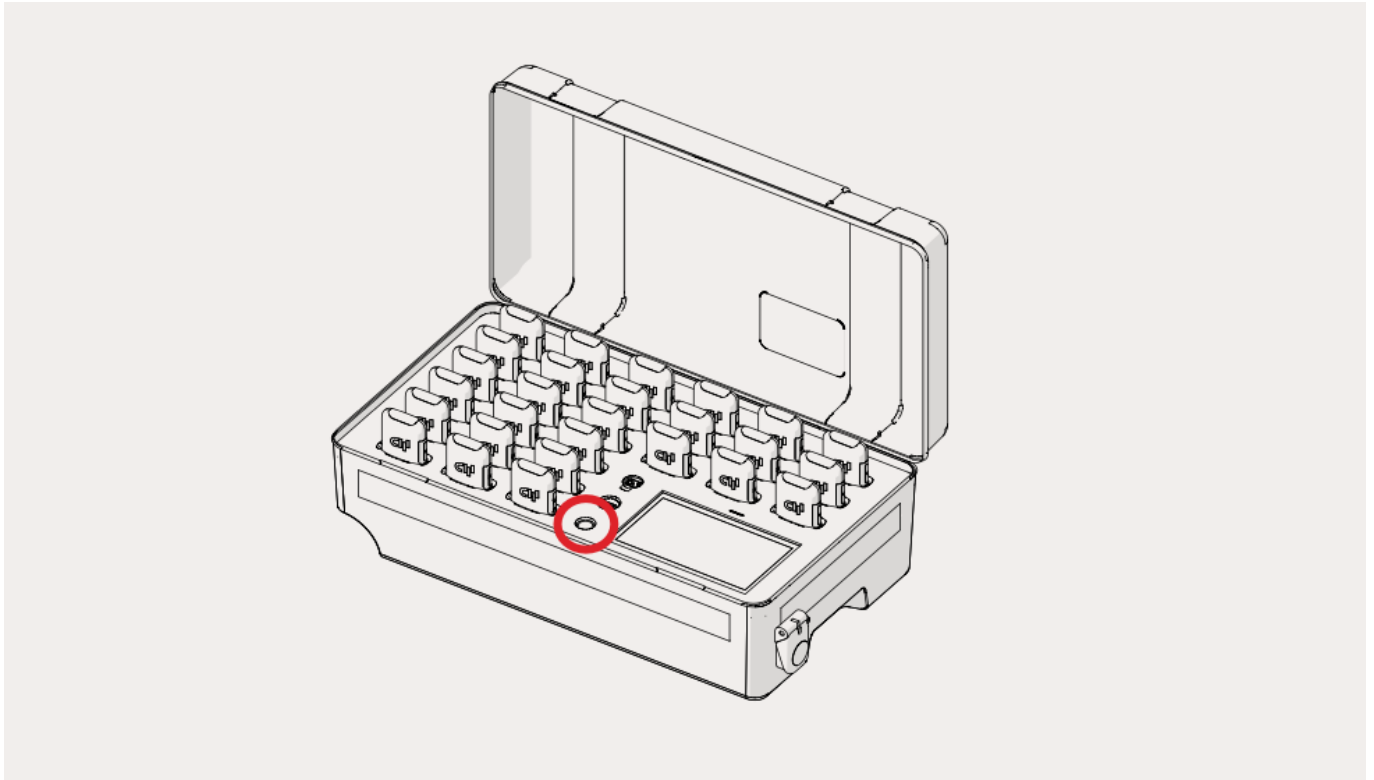

## Turn off the Cobox

1. Open the cover of the suitcase.
2. Press the ON / OFF button.

✓ A dialog to confirm the shutdown process opens for 20 seconds. (Note: If the shutdown is not confirmed within 20 seconds, the dialog closes again and the COBOX is not shut down)

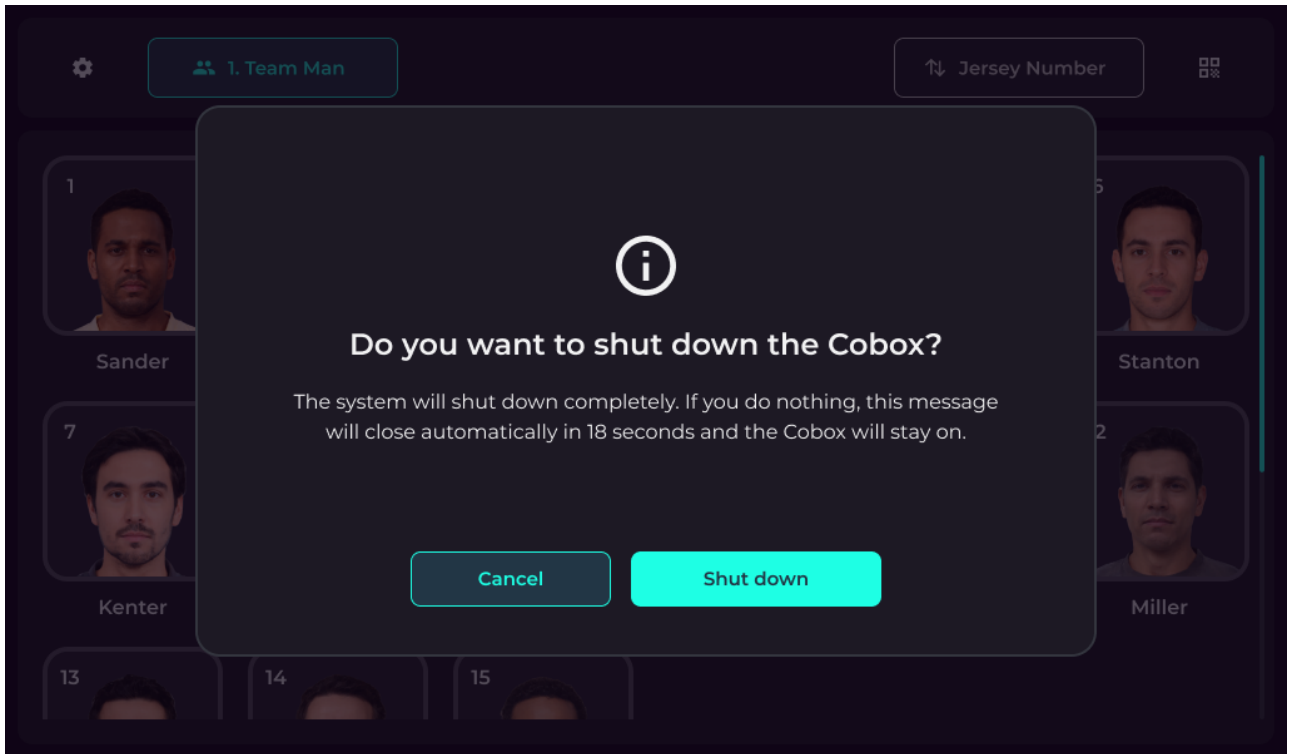

3. Press “Shut down” to turn off the COBOX.

✓ The COBOX shuts down.

## Shutdown in case of error

If an error has occurred or the box can no longer be operated normally for other reasons, it can be forced to switch off.

- Open the cover of the case.
- Press the ON / OFF button three times and hold the ON / OFF button for 5 seconds on the third time.

✓ The COBOX is forced to shut down.

## 5.4 Charge Audas

The AUDAs are charged via the supply connections within the COBOX.

Note:

The AUDAs are only charged when the COBOX is switched on or connected to the power supply via the power plug.

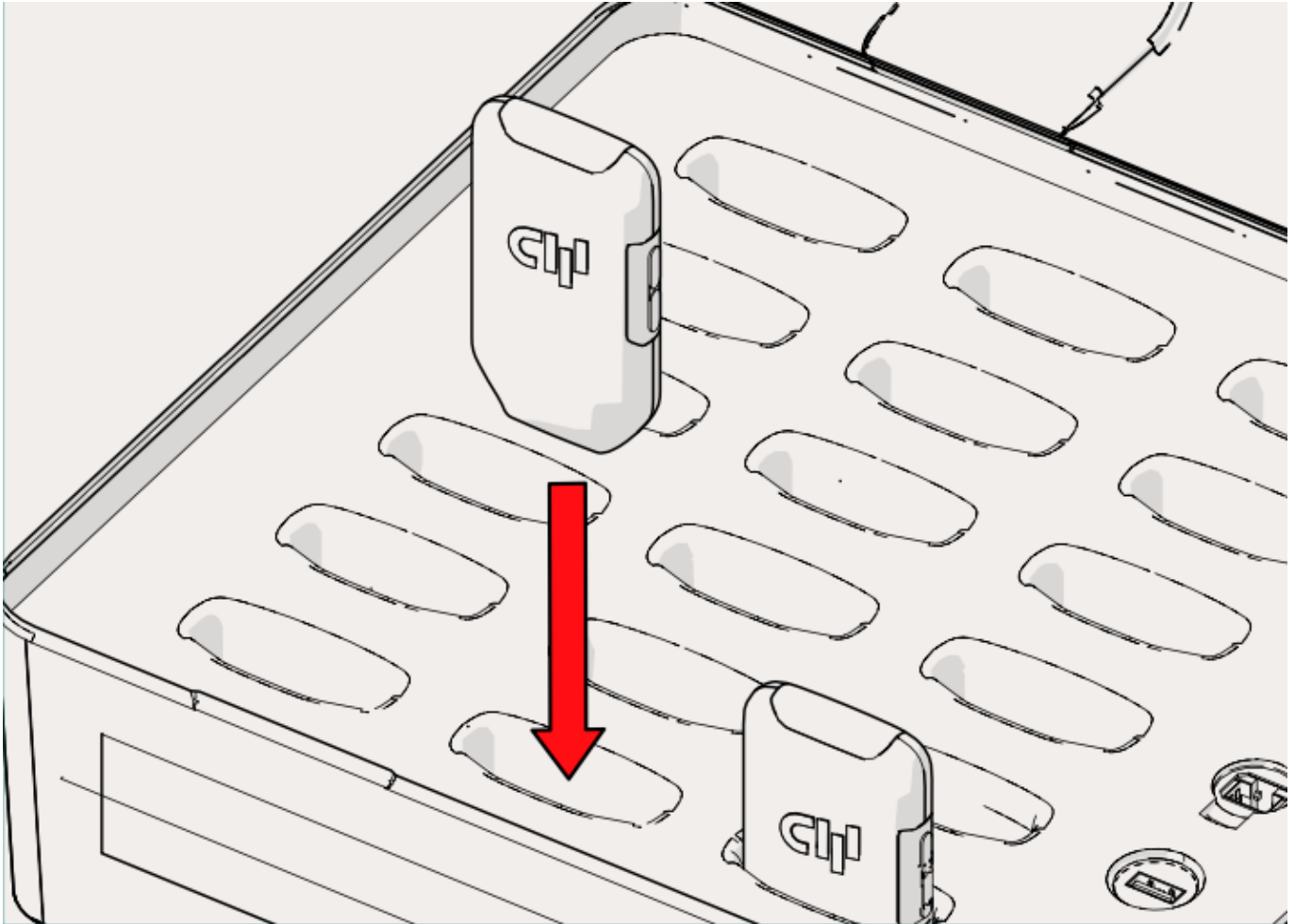

1. Open the cover of the case.
2. Insert the AUDA with the USB charging port into one of the designated slots.

- ✓ The AUDA is charging, the status indicator lights up yellow.
- ✓ When the AUDA is fully charged, the status indicator lights up green.

## 5.5 Download the Coach App

Install the app using the following QR code:



## 5.6 Settings and Wi-Fi connection

Set up the Wi-Fi on the COBOX for the first time or edit the Wi-Fi and screen settings.

- Press the gear icon in the top left corner of the screen.
- ✓ The Settings screen opens.
- Select the desired settings for display and language.

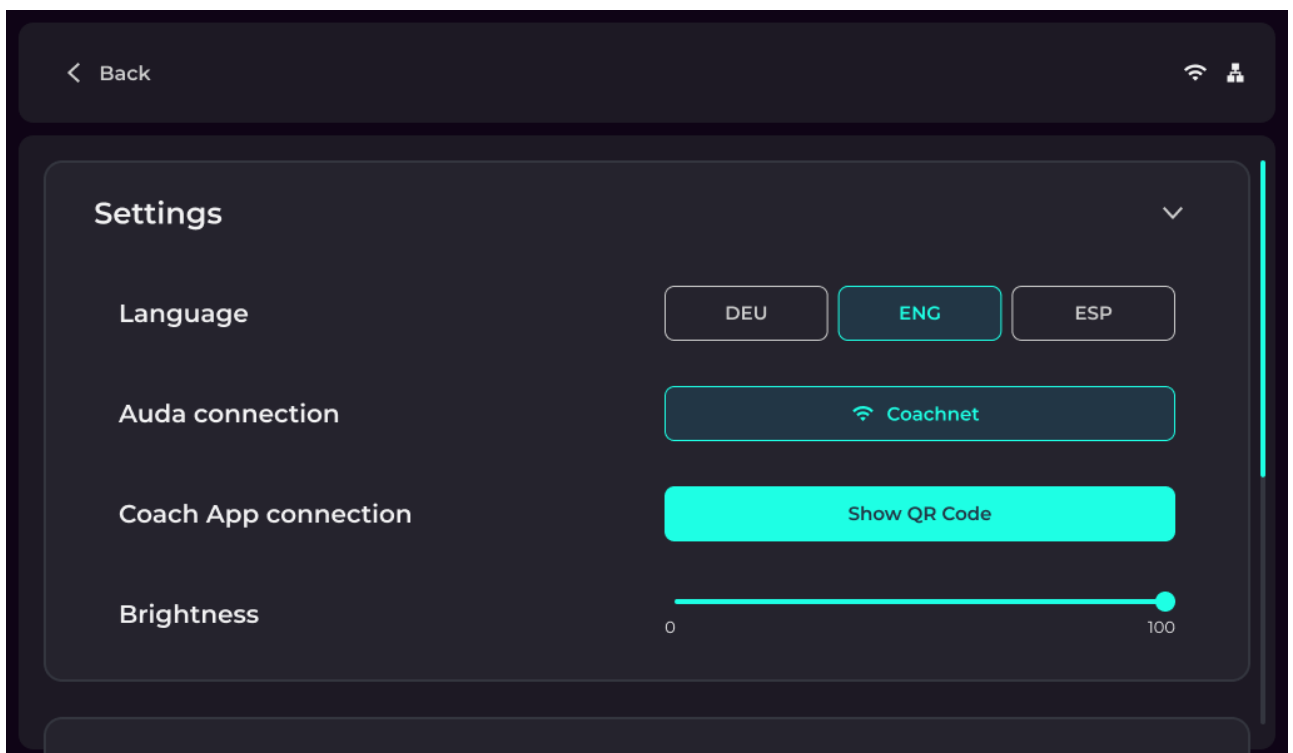

- Press the “Select Wi-Fi network” button.

- ✓ The Select Network screen opens.

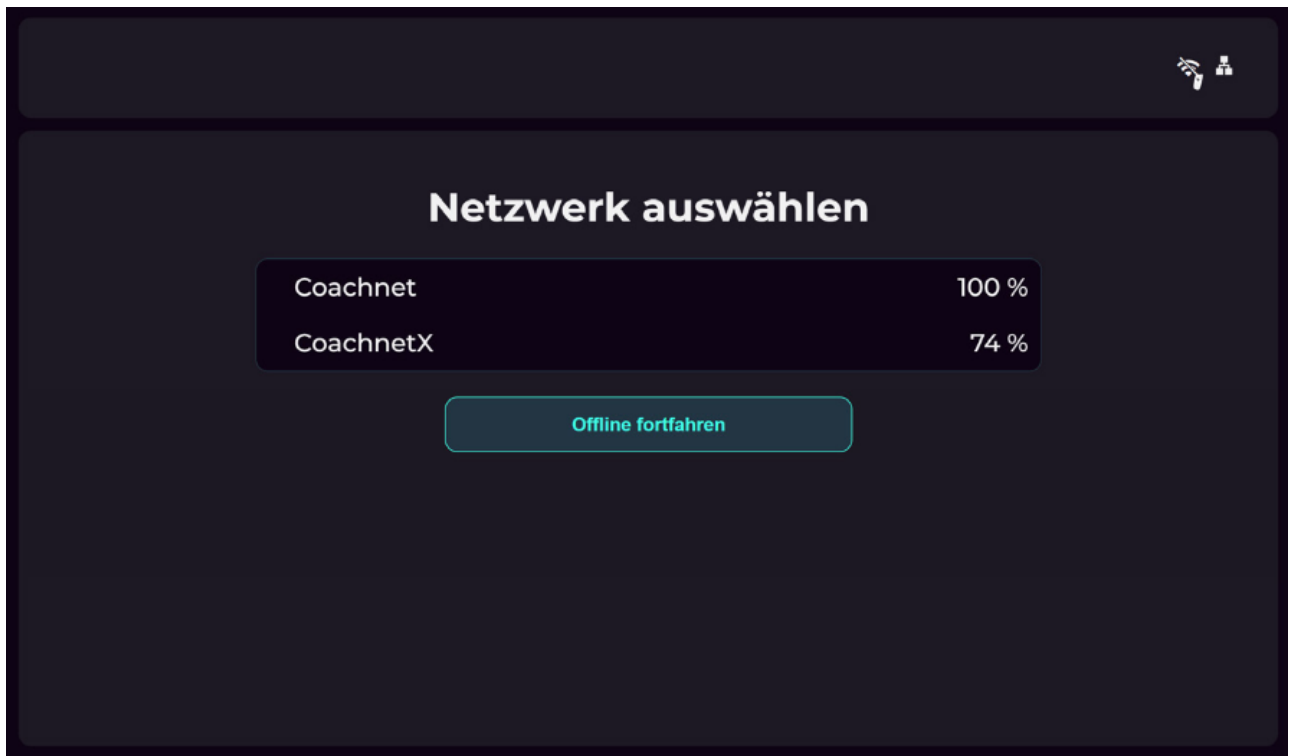

- Select a network from the list.
  - Enter a valid password using the (on-screen) keyboard to establish the Wi-Fi connection and press Connect.
- ✓ The COBOX transmits the WLAN login data to the AUDAS.
  - ✓ After successful login, the COBOX saves the last entered login data.

## 5.7 Using Cobox

- Once the Cobox is turned on, a popup with a QR code opens, Scan the QR code with the Coach App

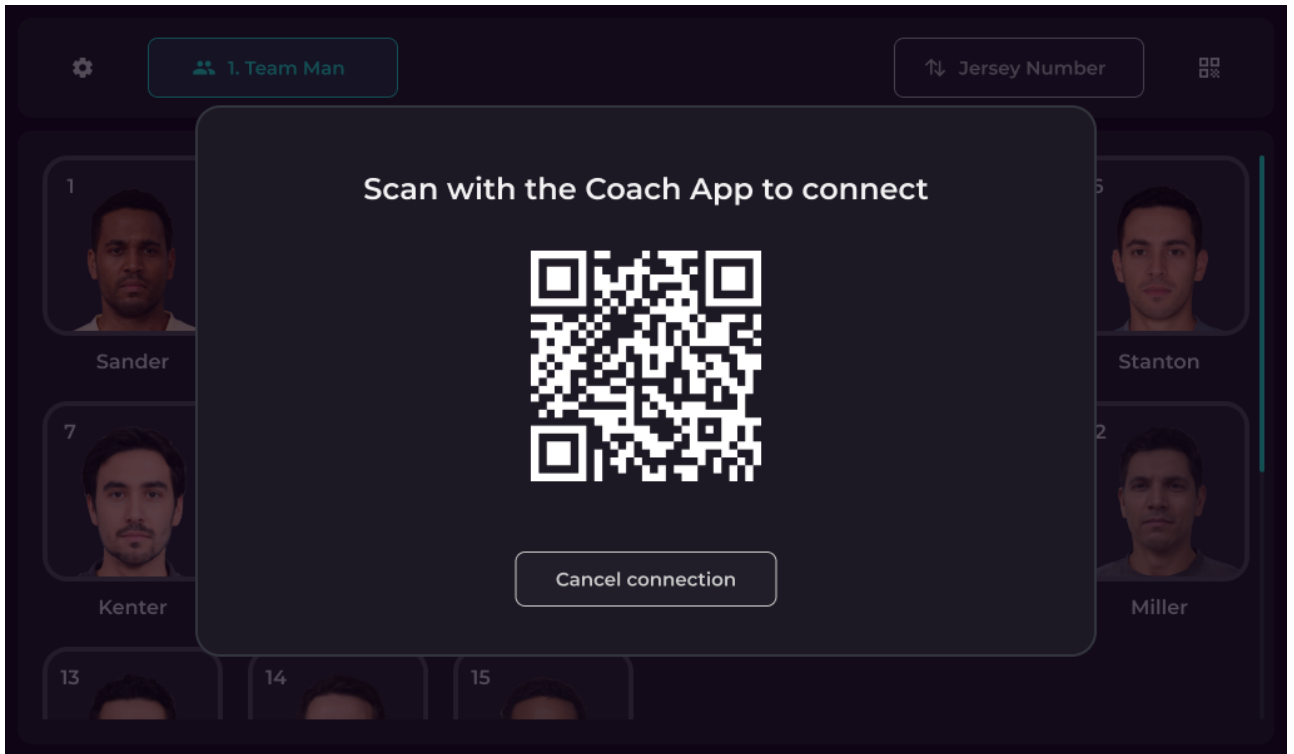

- If popup "Auda Update available" opens, click "Update" and wait until the process is complete.

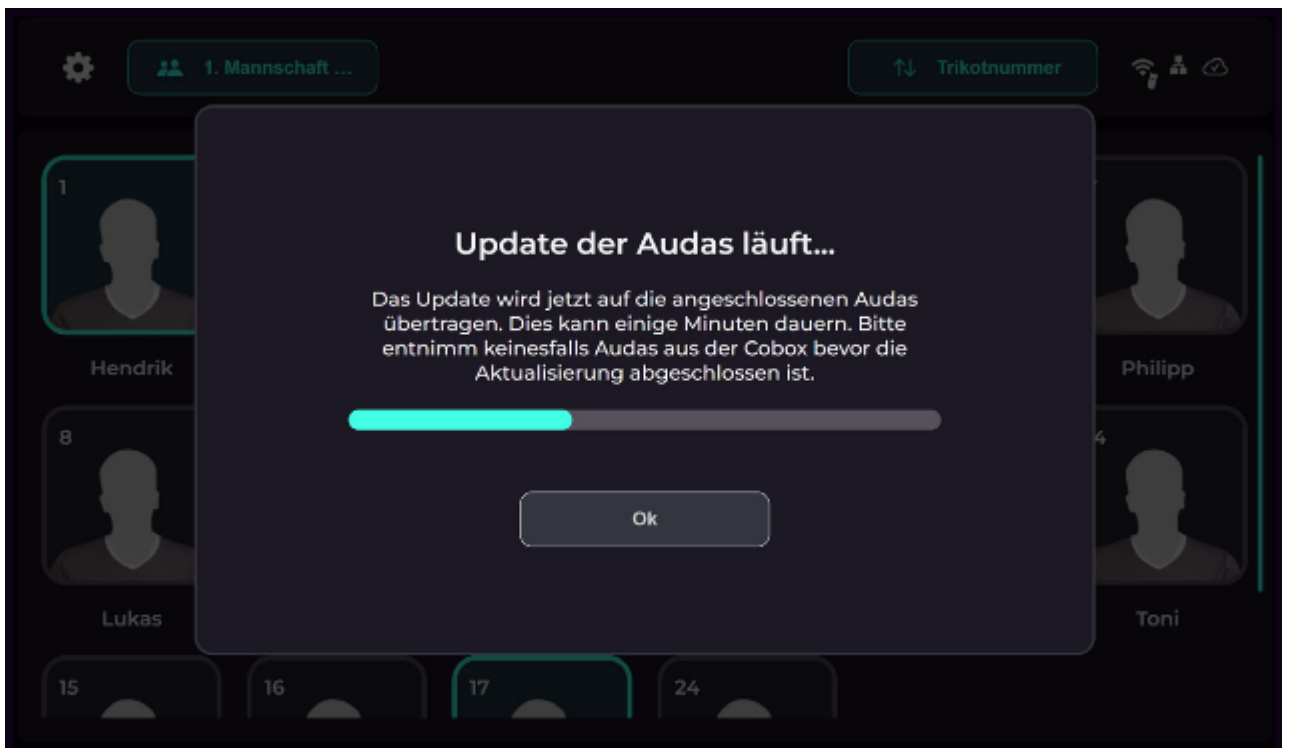

# 6 – Service

## 6.1 Control and display elements

### Touchscreen

The COBOX is equipped with a touchscreen, which is used to enter the operating inputs. The main screen shows the available player profiles of the selected team. The display can be customized using the team selection and sorting fields.

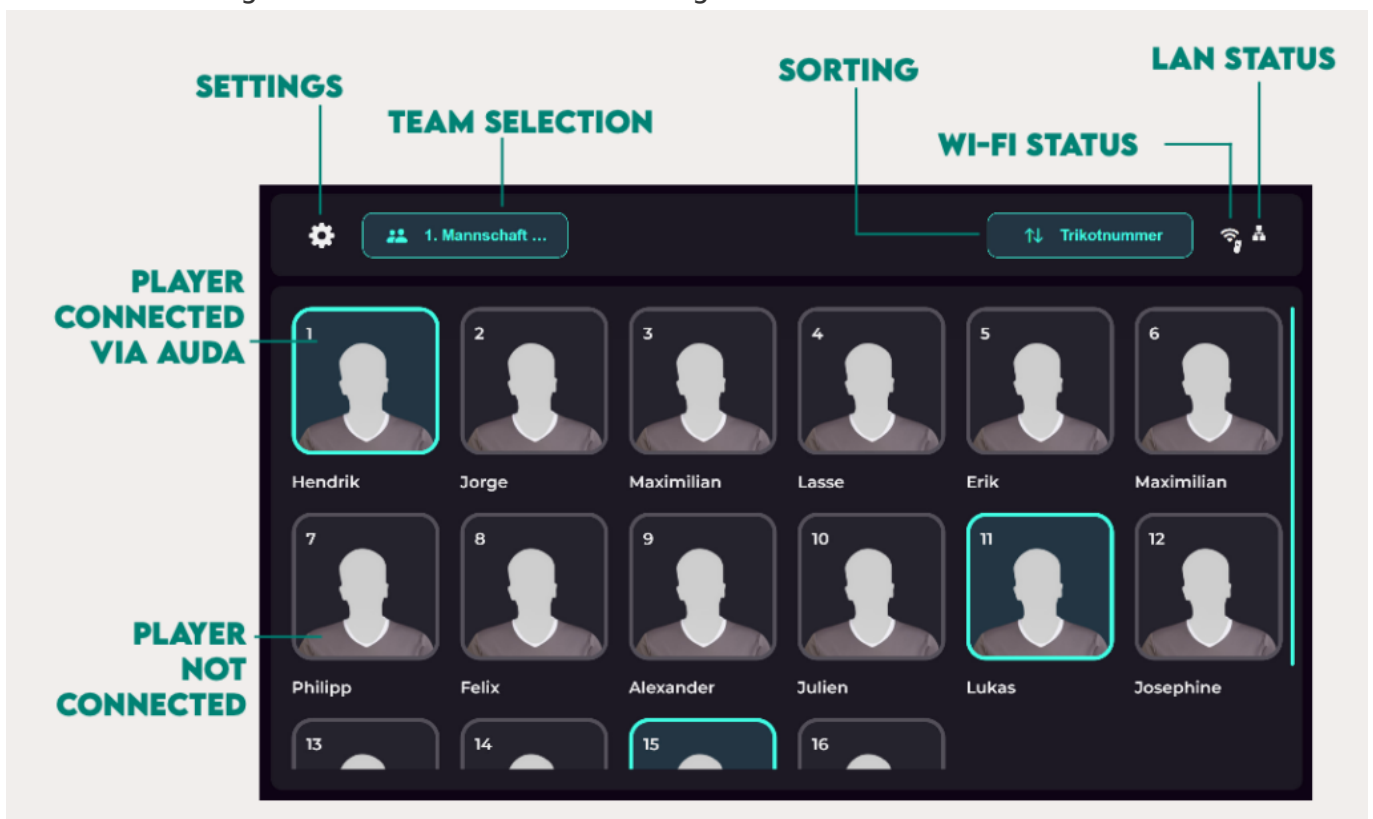

### Battery charge display Cobox

The COBOX battery charge indicator is located above the touchscreen and shows the battery charge when switched on or when the case cover is opened.

- 1 LED lights up: battery charge 0 – 20%



- 2 LED lights up: battery charge 20 - 40%
- 3 LED lights up: battery charge 40 - 60%
- 4 LED lights up: battery charge 60 - 80%
- 5 LED lights up: battery charge 80 - 100%

## Status display Auda

The AUDA battery charge and connection status indicator is located on the top of the AUDA. Depending on the connection status, the display lights up in the following colors:

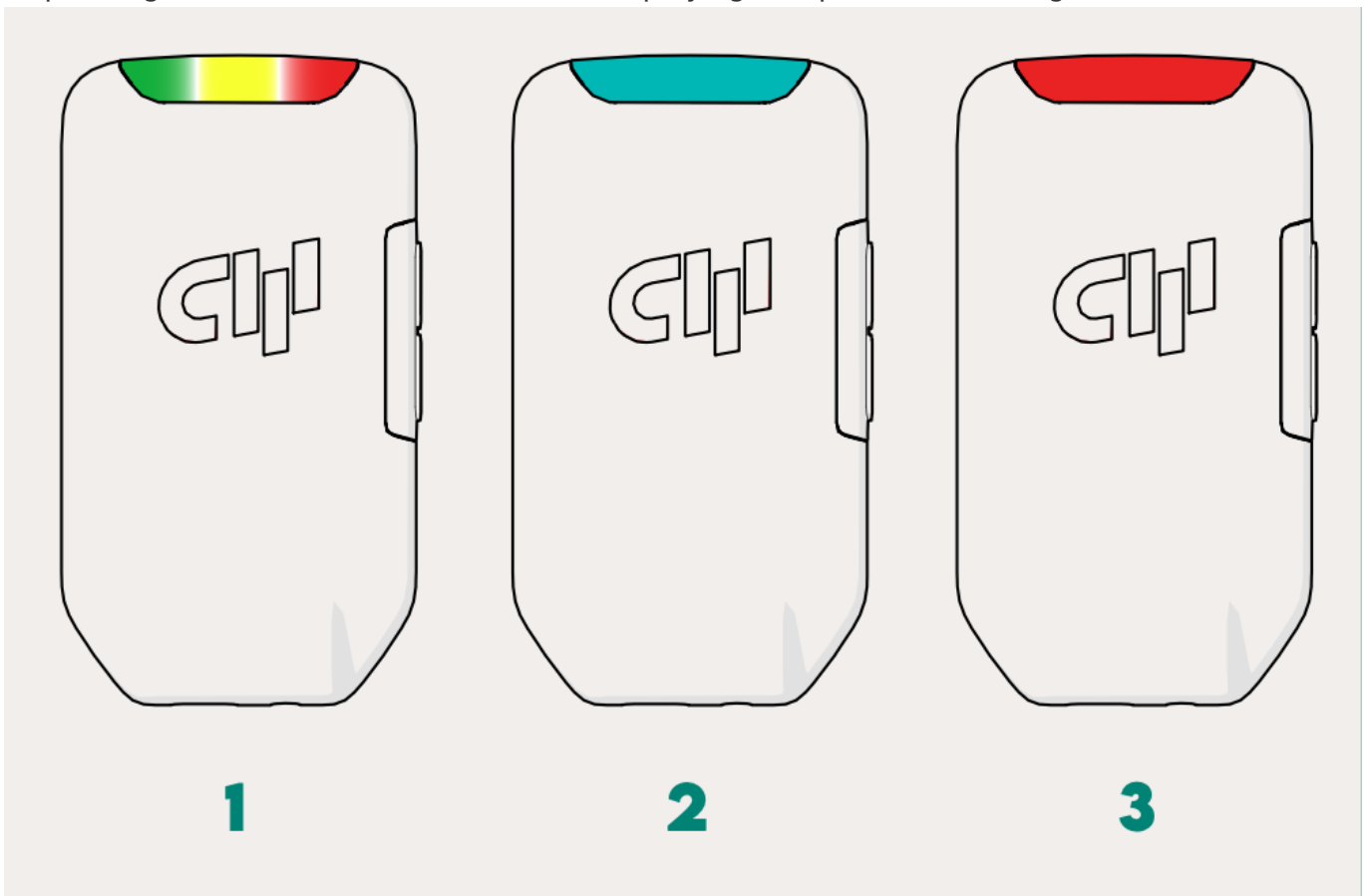

## Inside the Cobox (Cobox turned off)

- Off: AUDA is switched off and is not charging
- Flashing green (1): Fully charged, battery charge (running time over 1.5 hours)
- Flashing yellow (1): Charging in progress, battery charge > 20% (running time 15

min-1.5 hours)

- Flashing red (1): Charging in progress, battery charge < 20% (running time under 15 min)

## Inside the Cobox (Cobox turned on)

- Off: Active assignment on another device in COBOX
- Green solid (1): Fully charged, ready for assignment
- Yellow solid (1): Charging, ready for assignment
- Red solid (3): Error (contact customer service)

## Outside the Cobox

- Off: switched off
- Flashing green (1): Assigned, battery charge > 90% (running time over 1.5 hours)
- Flashing yellow (1): Assigned, battery charge 20-90% (running time 15 min-1.5 hours)
- Flashing red (1): Assigned, battery charge < 20% (running time under 15 min)
- Solid turquoise (2): Selected on the Coach app

# 6.2 Commissioning

## QR Code display / QR Scan

Once the Cobox is started, a QR code will appear on the screen. Open the Coach App on the iPad and scan the QR code to connect the Cobox to the App. The QR code can be accessed again in the settings.

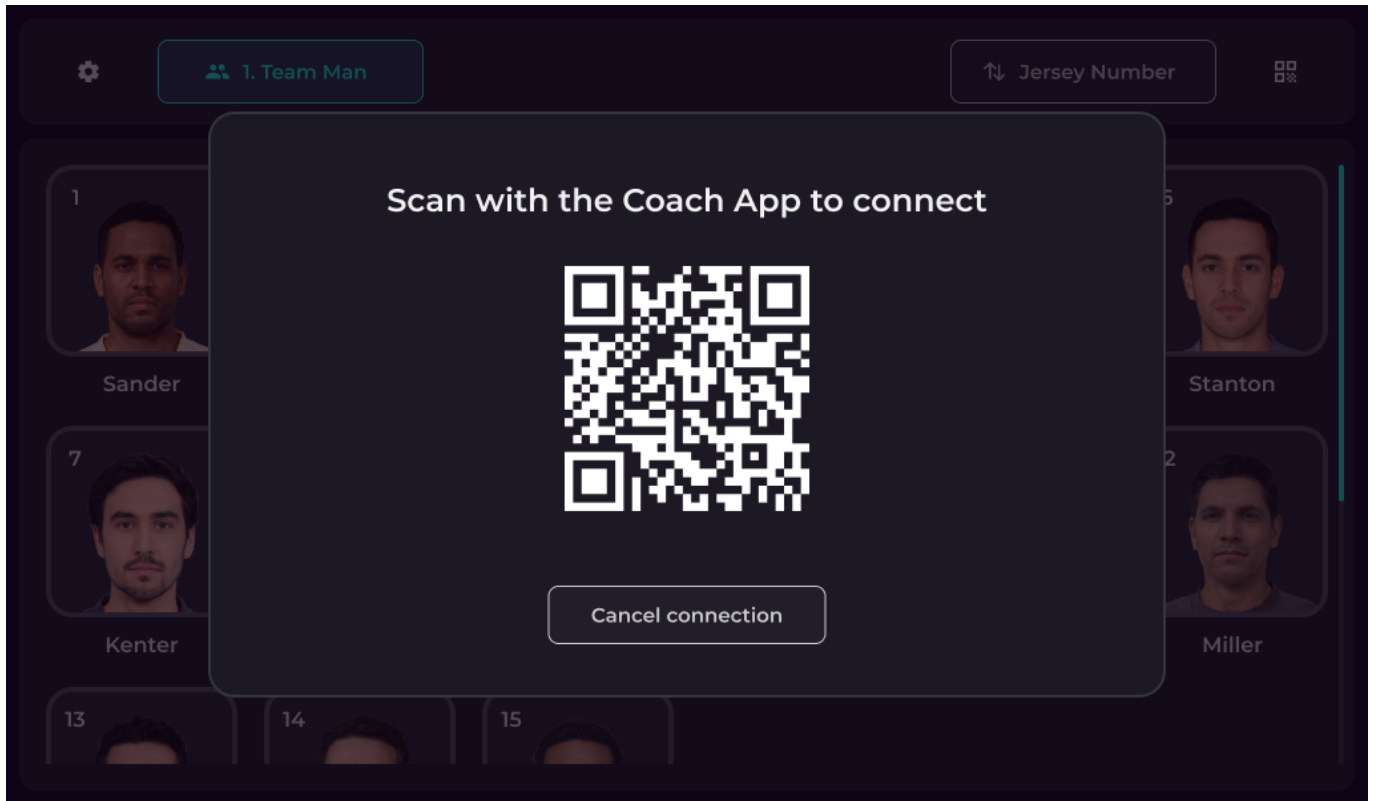

## Assign players

To assign the players in the Cobox, click on a player in the touchscreen and take the glowing Auda out of the Cobox. Each player is connected to their own Auda and will be shown in the Coach App.

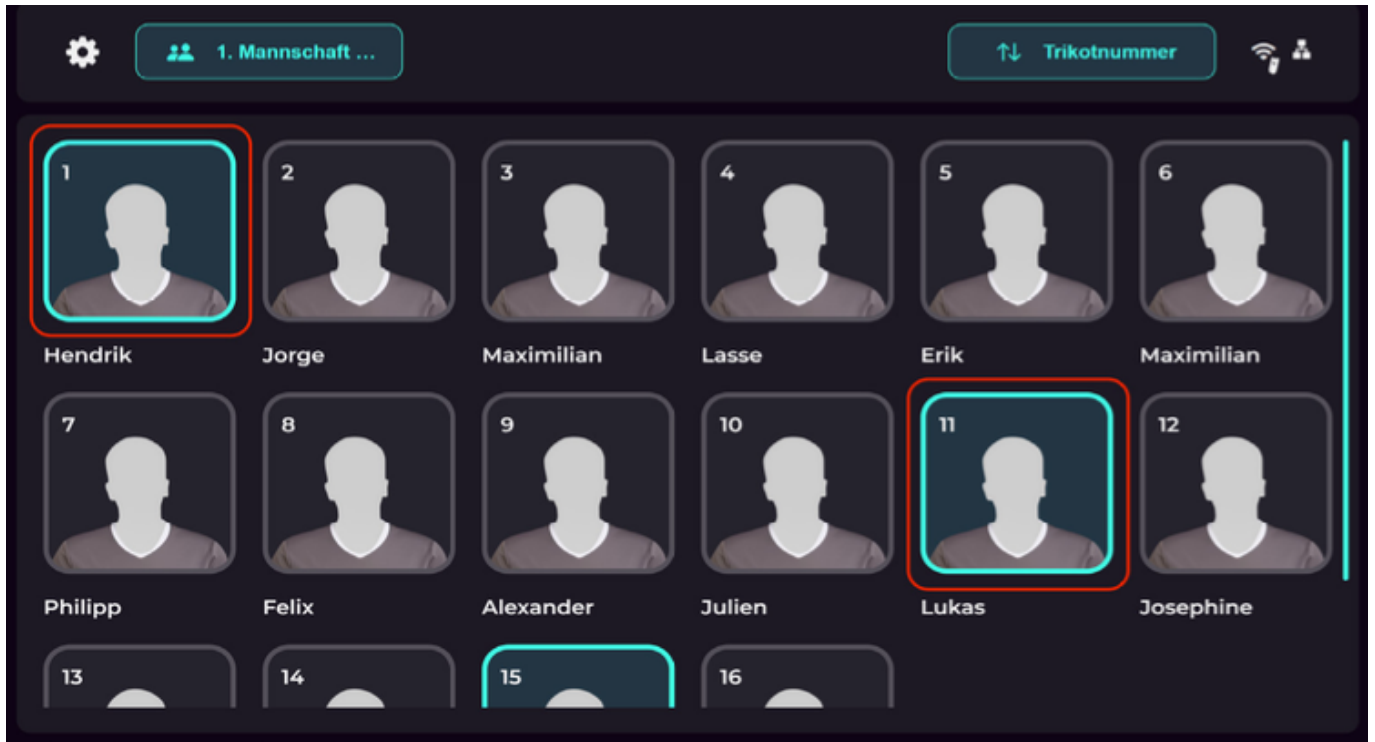

## Connect the Auda to the Soundvest

Place the Auda in the designated pocket (at the back) of the Soundvest. Make sure that the Auda is secure and firmly in place to ensure interference-free communication.



# Coach App: Selecting & communicating with players

On the Coach App, select the player you want to communicate with. Once the connection is established, speak directly to the selected players via the iPad.

## 6.3 Using the Coach App

### Login online

- Open the Coach App on your iPad.
- Select the option “Online Mode” in the welcome screen

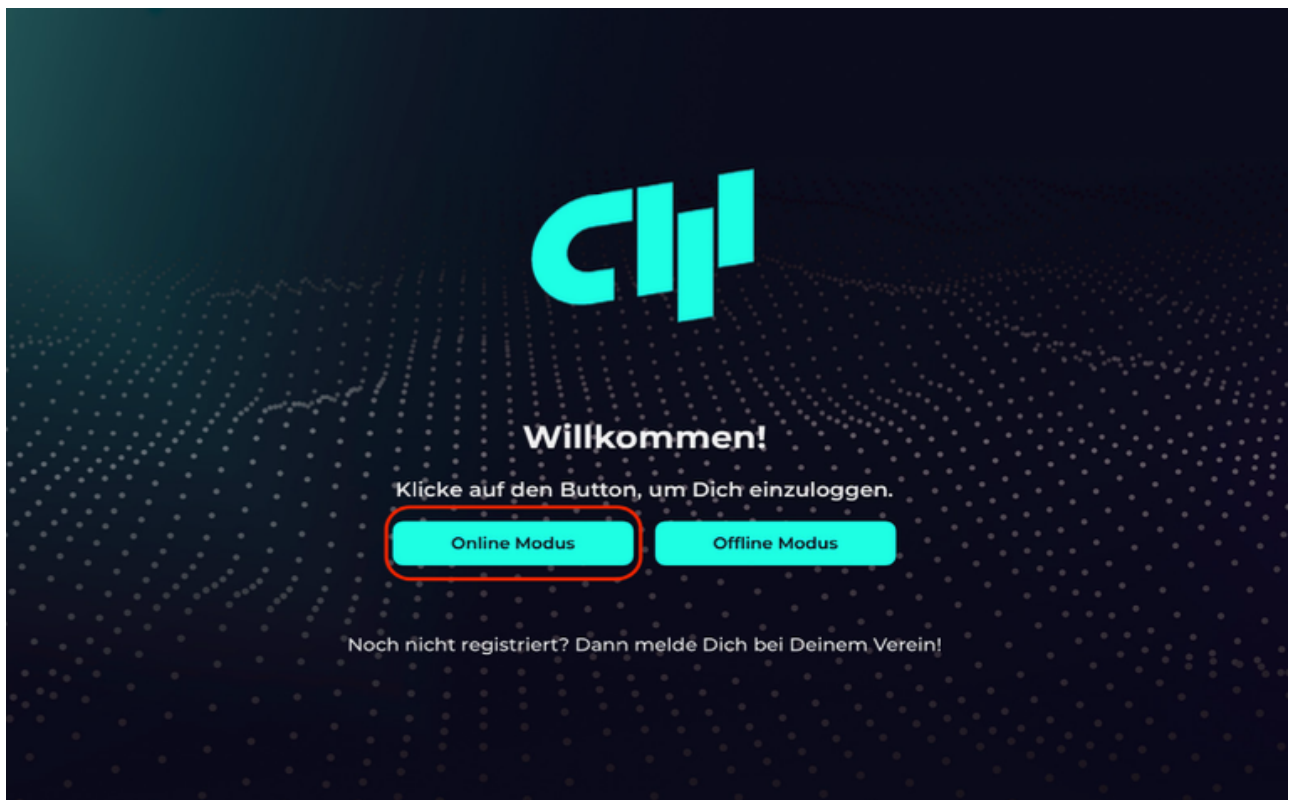

- Login screen appears. Enter email address, password and click “Continue” to log in.

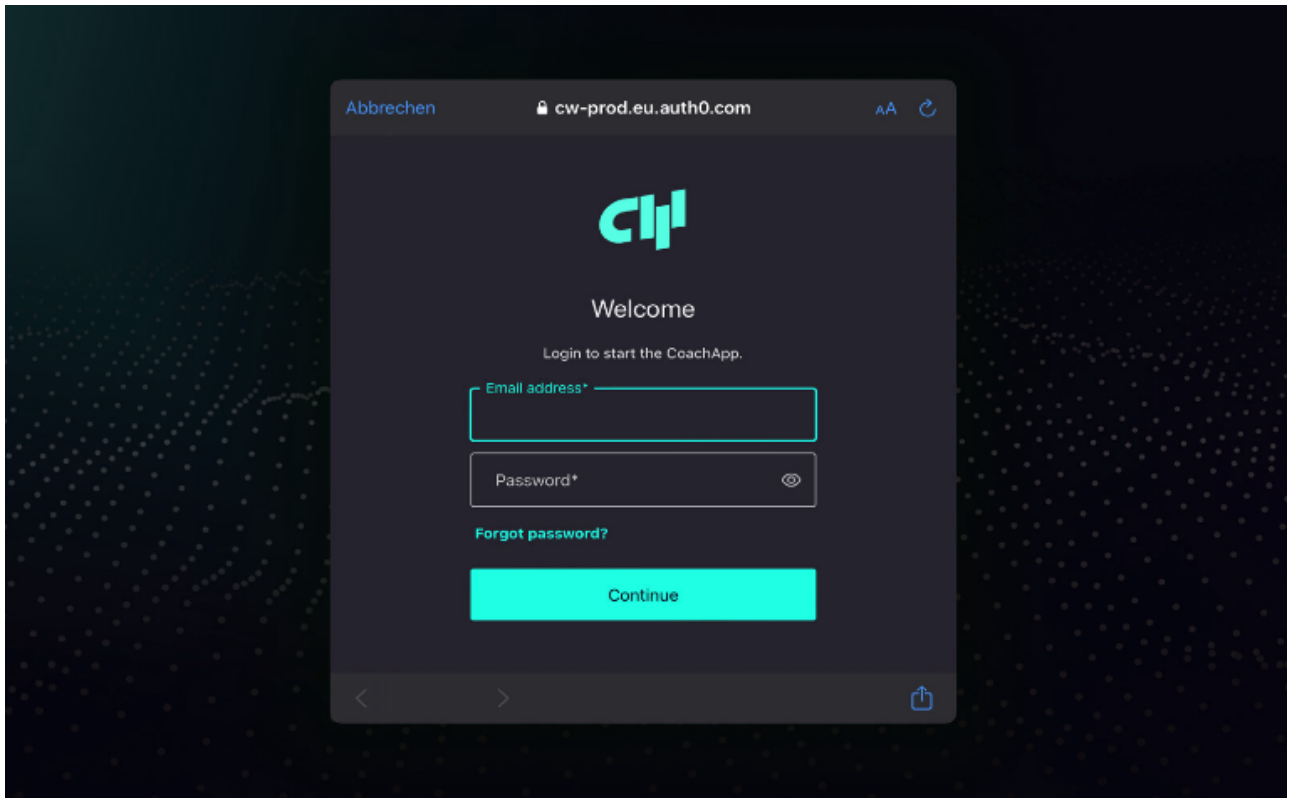

## Login offline

- Open the Coach App on your iPad.
- Select the option "Offline Mode" in the welcome screen

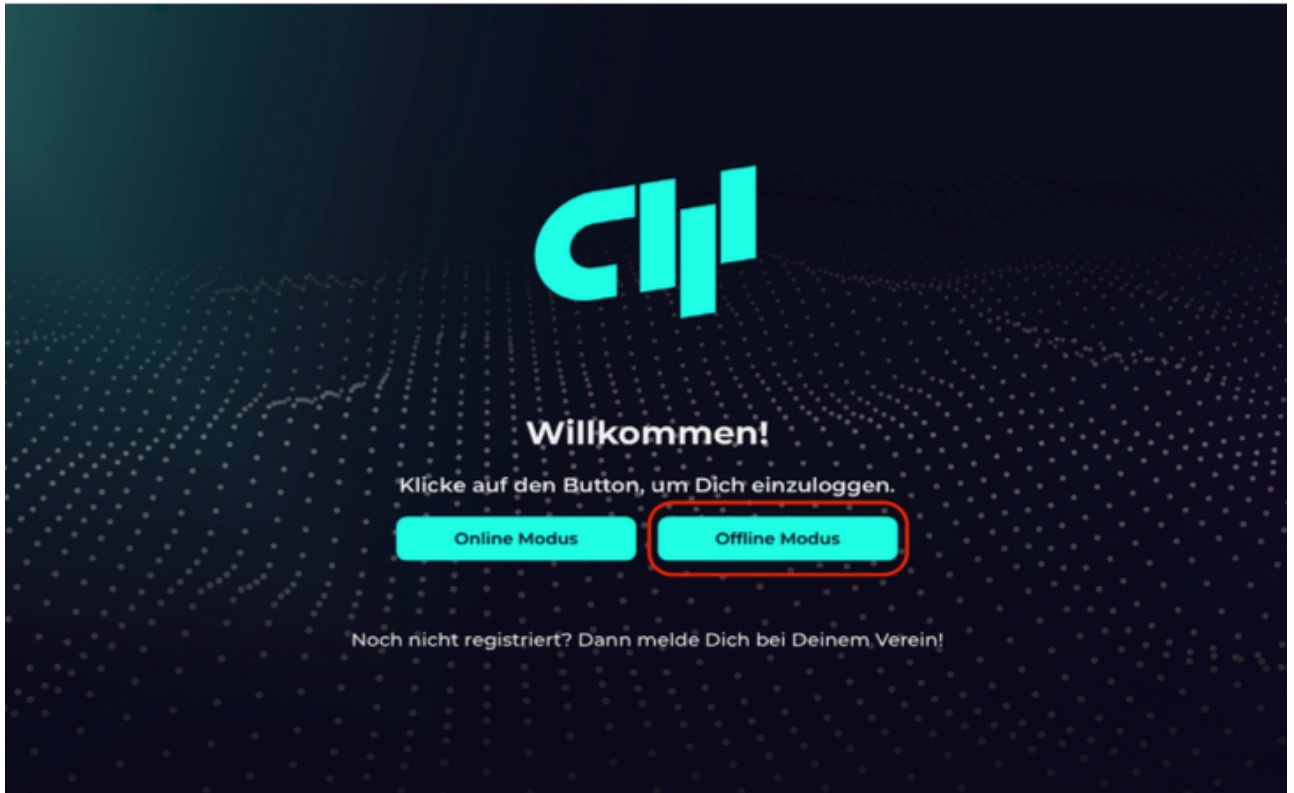

- Select account screen appears. Select your account from the list by clicking on it.

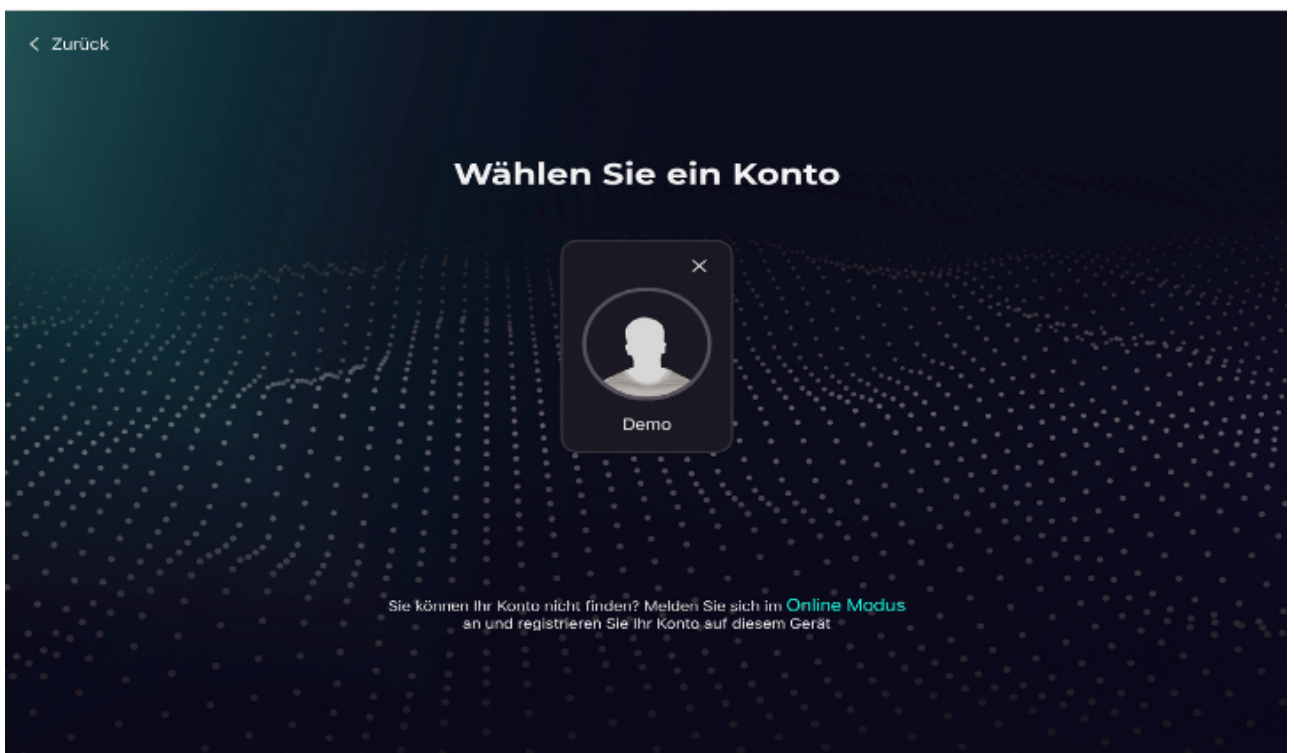

## Logout

- Open the Settings screen.
- In the lower right area of the screen, click the logout button to exit the current account.

